

Installation of a Remote Control Panel

Kits 300-4936, -4937, and -4938 are for Gasoline RV Generator Sets

GENERAL

These kits are for gasoline RV generator sets. They differ only in the type of remote panel included in the kit. Table 1 shows the type of panel contained in each kit. In addition to the remote panel assembly, this kit contains all mounting hardware.

The control circuitry is a 3-wire, ground-to-start/stop type. Before installing this kit, refer to the remote control panel wiring data in Figures 5, 6, and 7 and the wiring diagram specific to your application to confirm that this remote control kit is proper for your application. Consult an Onan distributor with any questions.

NOTE: Wiring must meet all applicable national and local codes. Have a qualified electrician install this kit.

TABLE 1. KIT PANEL TYPE

KIT NUMBER	PANEL TYPE	FIG NO.
300-4936	Start/Stop Switch only	1
300-4937	Start/Stop switch and Hour Meter	2
300-4938	Start/Stop Switch and DC Voltmeter	3

Read these instructions completely and become familiar with safety dangers, warnings, cautions, and procedures before starting the installation.

Place these instructions with the Operator's Manual when the job is done to document the changes made.

For personal safety and prevention of equipment damage, only qualified personnel should install this kit. The installer must wear safety glasses and protective clothing necessary for personal safety. Use the following procedure for installation.

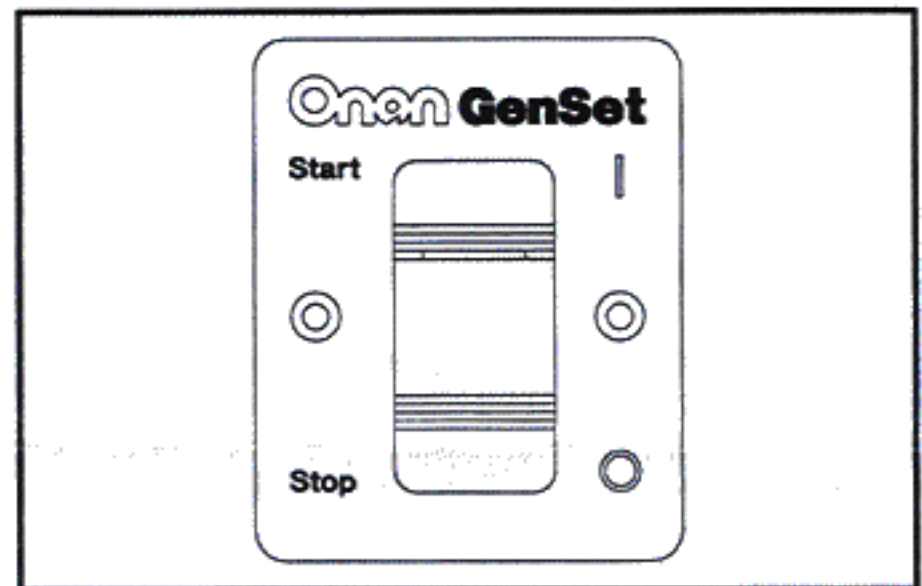

FIGURE 1. REMOTE CONTROL PANEL FOR KIT 300-4936

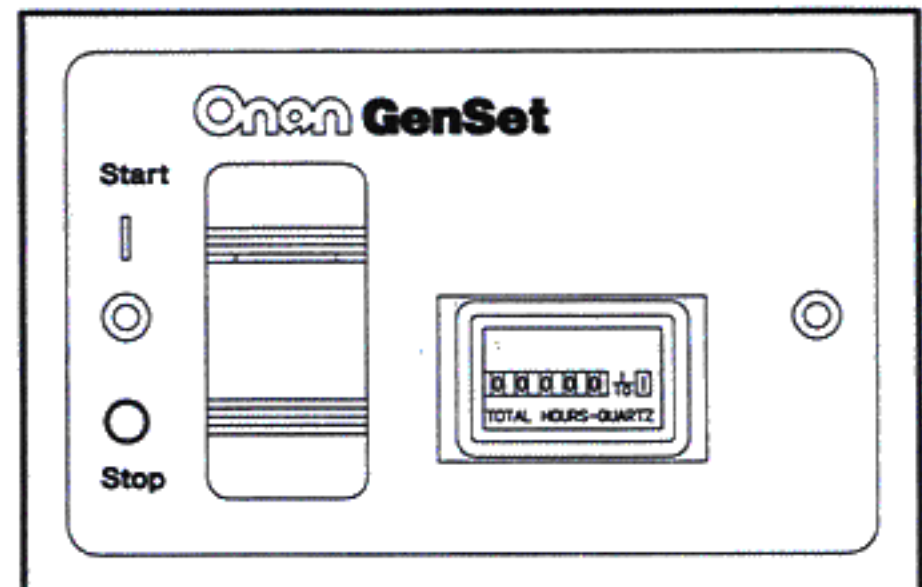

FIGURE 2. REMOTE CONTROL PANEL FOR KIT 300-4937

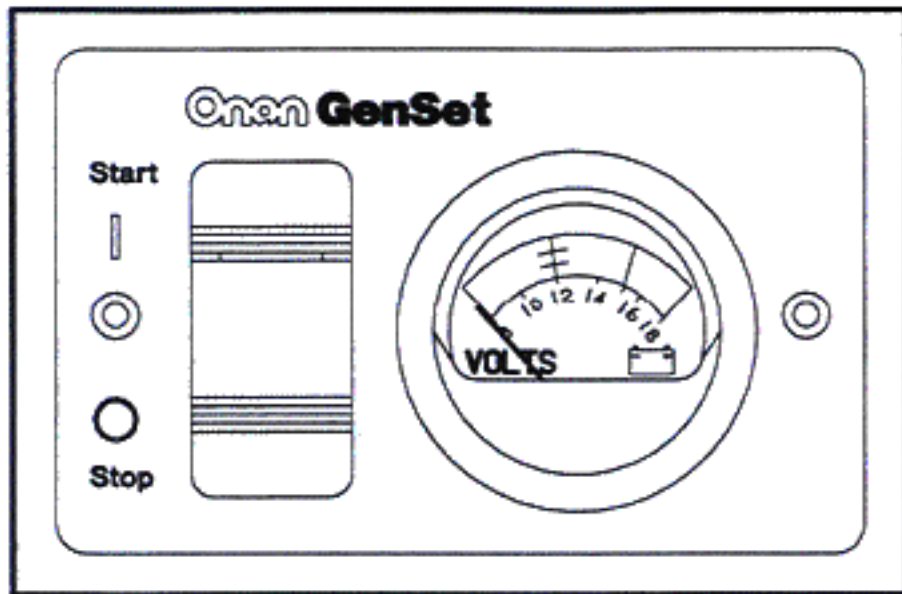

FIGURE 3. REMOTE CONTROL PANEL FOR KIT 300-4938

INSTALLATION

Preliminary

If a battery charger is connected to the battery, make sure it is unplugged from the AC power source *before* disconnecting the charger cables.

CAUTION Always disconnect a battery charger from its AC source before disconnecting the battery cables. Otherwise, disconnecting the cables can result in voltage spikes high enough to damage the DC control circuits of the set.

Disconnect the battery cables (negative [-] first) to prevent accidental starting while working on the set.

WARNING Accidental starting of the generator set while working on it can cause severe personal injury or death. Prevent accidental starting by disconnecting the starting battery cables (negative [-] first).

WARNING Arcing can ignite the explosive hydrogen gas given off by batteries, causing severe personal injury. Arcing can occur if the negative (-) battery cable is connected and a tool being used to connect or disconnect the positive (+) battery cable accidentally touches the frame or other grounded metal part of the set. To prevent arcing, always remove the negative (-) cable first, and reconnect it last.

WARNING Exhaust gases are poisonous and present the hazard of severe personal injury or death. Seal all holes to prevent entrance of exhaust gases into the vehicle interior.

CAUTION When DC wires are run with AC wires, electrical induction can occur and cause operational problems. Route remote control harness separately from AC load wires.

C537

Page 2 of 10

Preparation

1. Select a location for the remote:

- Use the proper template in Figure 8 and the remote control panel itself to determine a proper fit at the desired location. Note that the remote control panel requires a cutout be made to enable the control panel components to be inset and holes to be drilled for fasteners.
- Check the backside (inside) of the chosen location to ensure that nothing will interfere with the drilling and cutting operations, or with the fasteners and control panel inset components when mounted.
- Determine the feasibility of routing the control wires from the genset to the remote control panel location. Ensure that the route of the control wires meet all applicable national and local codes. Wires must be protected from all hot, sharp, and abrasive surfaces.

WARNING Exhaust gases are poisonous and present the hazard of severe personal injury or death. Seal all holes to prevent entrance of exhaust gases into the vehicle interior.

CAUTION When DC wires are run with AC wires, electrical induction can occur and cause operational problems. Route remote control harness separately from AC load wires.

- Review preceding Steps 1a through 1c to determine if an alternate location for the remote control panel should be selected.
2. Prepare the chosen location for the remote control panel. Be sure to use the proper template from Figure 8.
- Cut out the proper template from Figure 8.
 - Tape the template to the mounting surface to be cut out, make sure that the template is "square" with the mounting surface.
 - Using a center punch and a hammer, punch a mark through the template for each fastener and at the four corners of the cutout area.
 - Remove the template.

3. Drill the cutout starter holes at the four corners of the cutout area. Cut between them and remove the cutout.

NOTE: Because the location of the remote control panel will vary by installation, the tools to be used and cutout material (wood, metal, plastic, etc.) will differ. Therefore, the size of the cutout starter holes and the procedure for cutting between the starter holes must be determined by the installer.

4. Drill 1/16-inch diameter holes for the control panel fastening screws.
5. This completes preparation of the mounting hole for the remote control panel.

Interconnecting Harness

There are four methods to provide the harness to connect the remote control panel to the genset:

- Two ready-made harnesses are available from Onan to connect the remote control panel to the genset. See Figure 4.
- Modify either of the ready-made harnesses by cutting them and splicing in user supplied wires of additional length. See Figure 4.
- Connectors with pig-tails for both the control panel end and the genset end are available from Onan to connect to user supplied intermediate wires. Connectors are identical to those shown in Figure 4.
- Connectors and end terminals (not assembled) for both the control panel end and the genset end are available from Onan and the supplier to connect to user supplied intermediate wires. This method is recommended only for high volume users. Connectors are identical to those shown in Figure 4.

See the Onan RV Accessories Catalog for the part numbers of the above Onan components.

Ready-Made Harness Method

The ready-made harnesses can either be used as is or modified by cutting them and splicing in user supplied wires of additional length. See Figure 4.

When modifying a ready-made harness, follow these steps:

1. Cut the harness at a point that will easily allow the additional wire to be spliced in.
2. Attach the harness connectors to their corresponding connectors at each end.
3. Carefully measure the distance between the cut ends of the harness, following the route that the harness will have to follow.
4. Add on some additional length (not less than 1 foot) for slack in the harness.
5. Cut the required number of wires to this length. Use 18-gauge stranded, insulated automotive wire.
6. Connect the wires to the harness ends using automotive in-line, crimp-type splices. It is recommended that heat-shrink tubing be installed over each splice to protect it from corrosion.
7. Make sure that the wire orientation is correct.

CAUTION *Incorrect connections can damage genset controls, remote devices, and interconnecting wiring. Ensure that the leads between the connectors are properly connected.*

8. Use tie wraps at 20-inch intervals to keep the wire bundle neat.

Connectors with Pig-Tails Method

1. Carefully measure the distance between the remote panel connector and the genset connector, following the route that the harness will have to follow.
2. Add on some additional length (not less than 1 foot) for some slack in the harness.
3. Cut the required number of wires to this length. Use 18-gauge stranded, insulated automotive wire.
4. Connect the wires to the pig-tails on the connectors using automotive in-line, crimp-type splices. It is recommended that heat-shrink tubing be installed over each splice to protect it from corrosion.
5. Make sure that the wire orientation is correct.

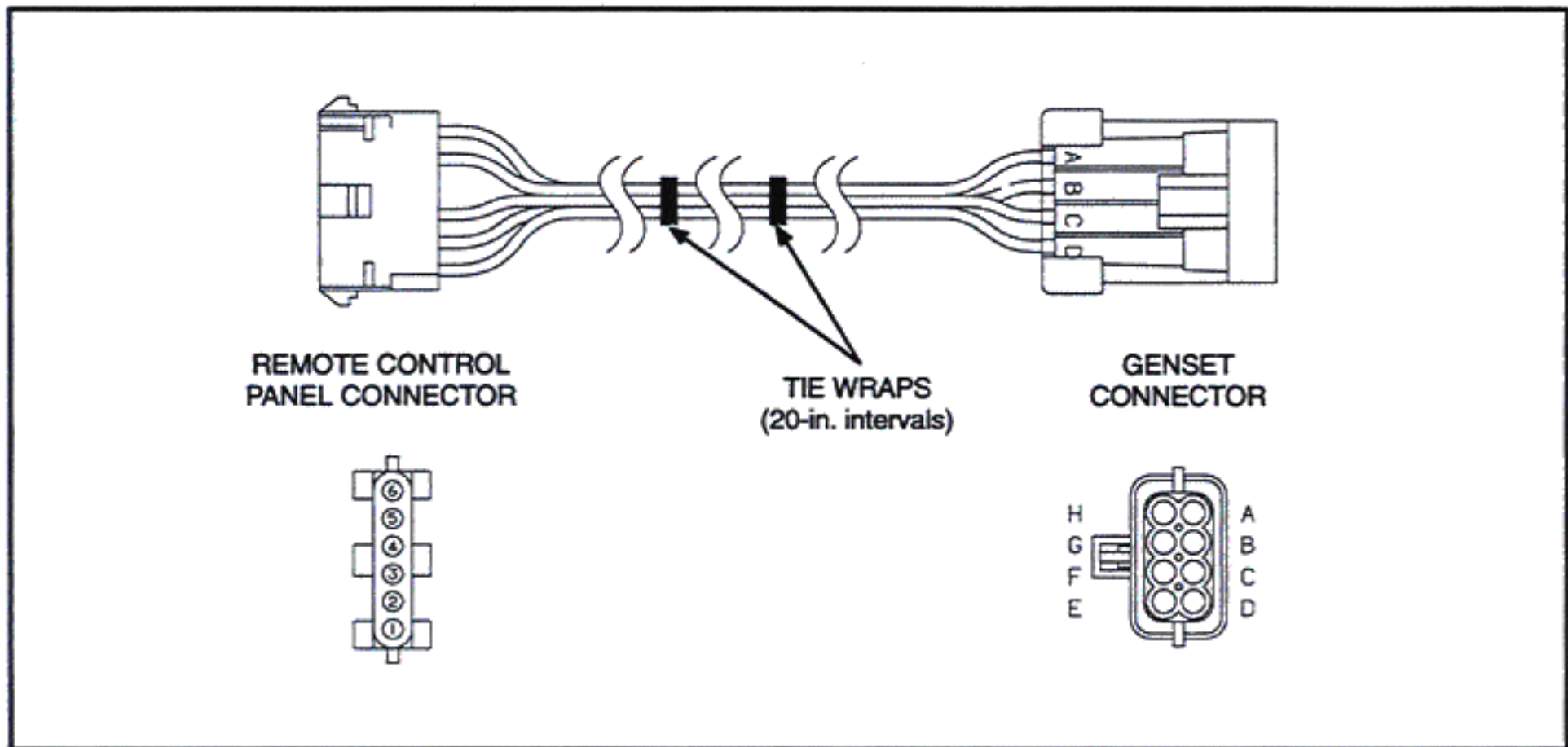

FIGURE 4. REMOTE PANEL HARNESS

CAUTION *Incorrect connections can damage genset controls, remote devices, and interconnecting wiring. Ensure that the leads between the connectors are properly connected.*

- Use tie wraps at 20-inch intervals to keep the wire bundle neat.

Connectors Only Method

- Carefully measure the distance between the remote panel connector and the genset connector, following the route that the harness will have to follow.
- Add on some additional length (not less than 2 feet) for some slack in the harness.
- Cut the required number of wires to this length. Use 18-gauge stranded, insulated automotive wire.
- Connect the wires to the connector terminals, using the proper crimping tool.

NOTE: Crimping tools and complete instructions are available from AMP® and Packard Electric dealers.

- At the remote panel end of the harness, insert the panel terminals and attached wires into the panel connector body
- At the genset end of the harness, determine which terminal goes into which position in the connector body by referring to Figures 5, 6, and 7 for the panel connector terminal locations and to Table 2 for the corresponding genset terminal locations. Refer to Figure 4 for the genset connector terminal locations. Make sure to properly install wire seals and plugs in the genset connector to form a water-tight seal.

TABLE 2. GENSET/PANEL CONNECTOR TERMINAL RELATIONSHIPS

PANEL CONNECTOR TERMINAL	GENSET CONNECTOR TERMINAL
1	A
2	B
3	C
4	D
5	E
6	F

CAUTION *Incorrect connections can damage genset controls, remote devices, and interconnecting wiring. Ensure that the leads between the connectors are properly connected.*

- Use tie wraps at 20-inch intervals to keep the wire bundle neat.

Harness Installation

- Route the harness from the genset to the remote control panel, making sure that the connectors on the harness match the corresponding connectors at each end. Wires must be protected from all hot, sharp, and abrasive surfaces.

CAUTION When DC wires are run with AC wires, electrical induction can occur and cause operational problems. Route remote control harness separately from AC load wires.

- Plug any holes where the harness passes through bulkheads.

WARNING Exhaust gases are poisonous and present the hazard of severe personal injury or death. Seal all holes to prevent entrance of exhaust gases into the vehicle interior.

- Connect the harness genset connector to the genset connector.

- Pass the harness remote control panel connector through the cutout for the control panel.
- Connect the harness remote control panel connector to the control panel connector.
- Insert the control panel in the cutout hole and secure with screws from the kit.
- This completes the remote control panel installation.

TESTING

- Reconnect the genset negative (-) battery cable.
- Start and stop the genset at the genset control.
- Start the genset at the remote control panel and check the following:
 - Genset starts and continues to run.
 - The indicator lamp in the remote switch illuminates when the genset is running.
 - The hour meter runs, if so equipped.
 - The DC voltmeter registers, if so equipped.

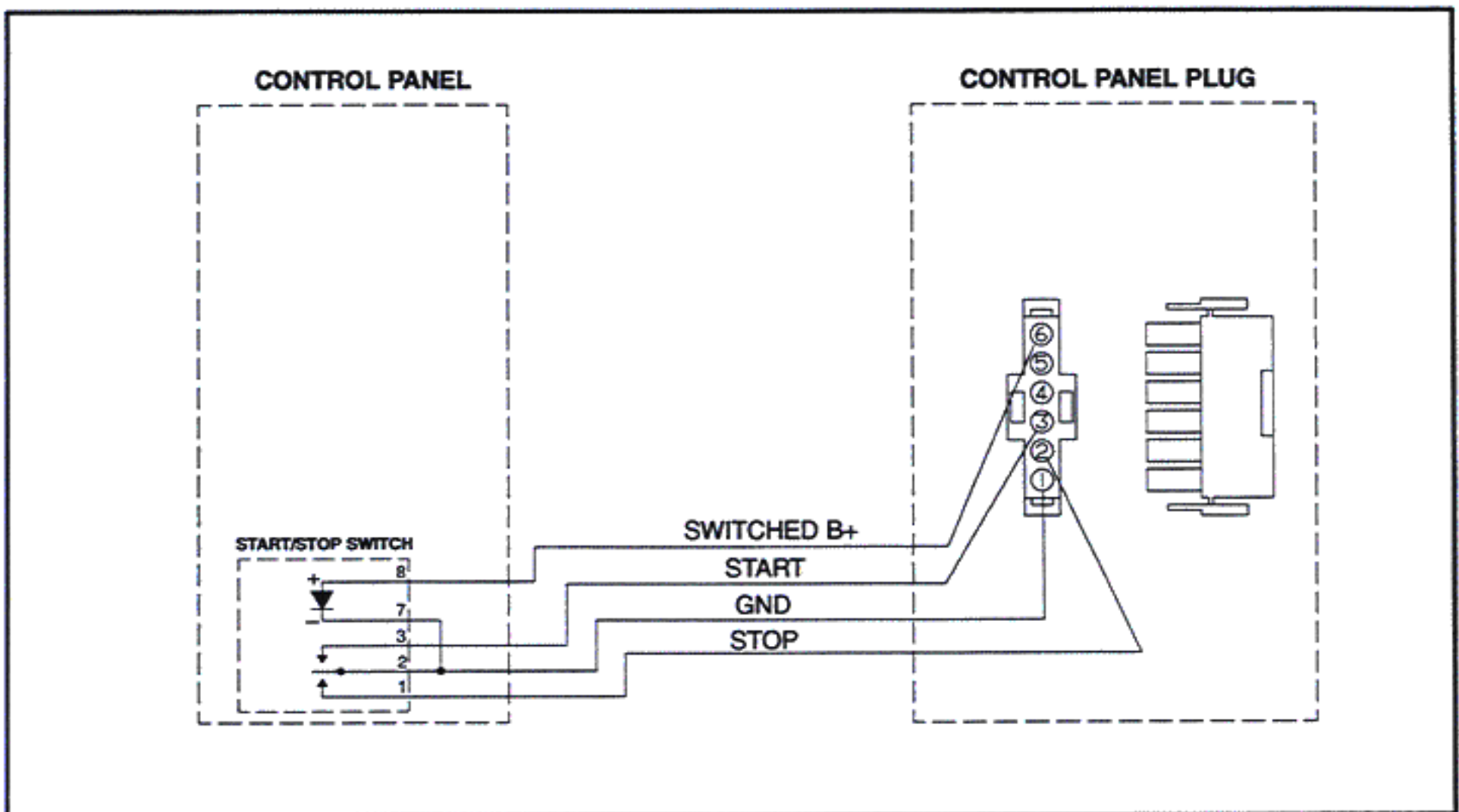

FIGURE 5. KIT 300-4936 REMOTE CONTROL WIRING DIAGRAM

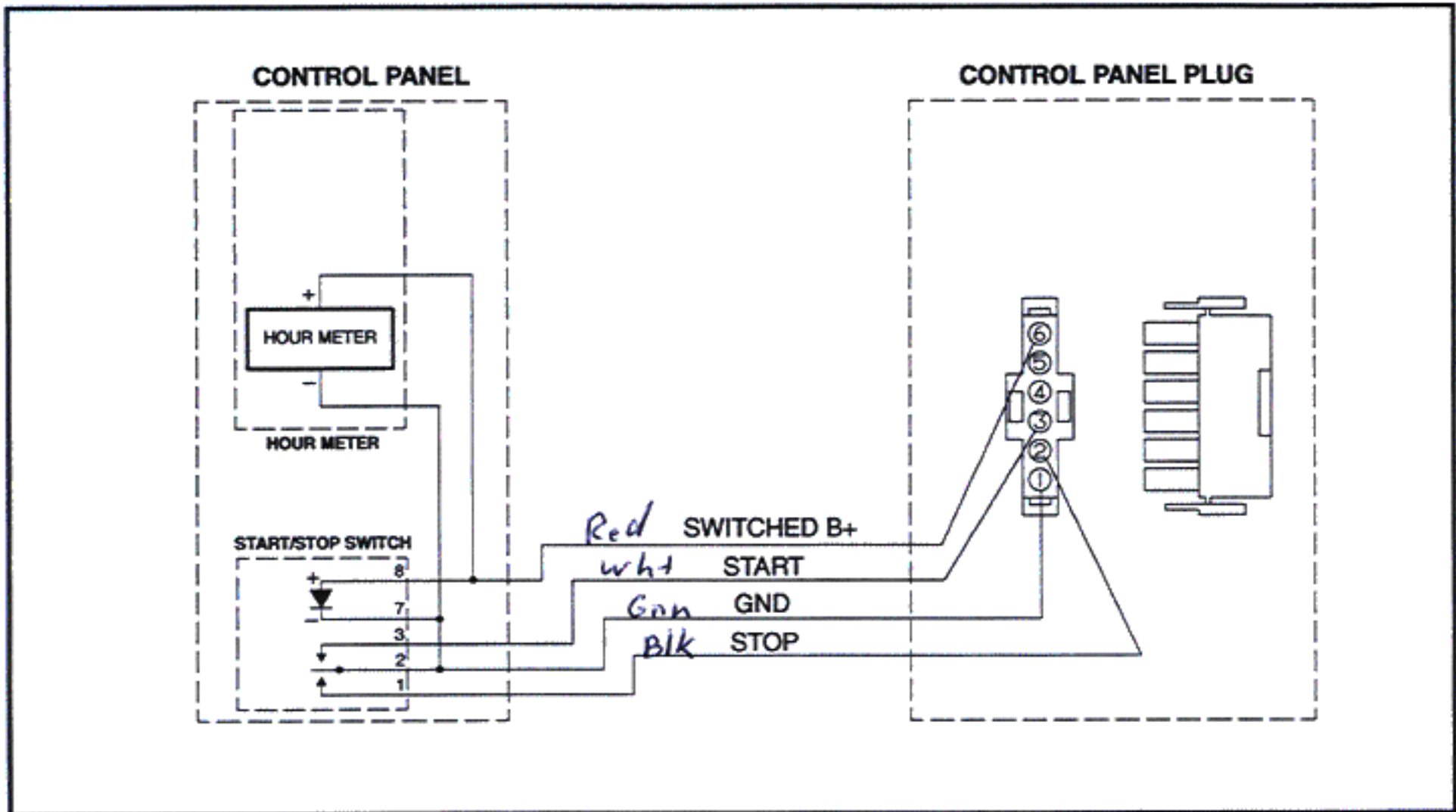

FIGURE 6. KIT 300-4937 REMOTE CONTROL WIRING DIAGRAM

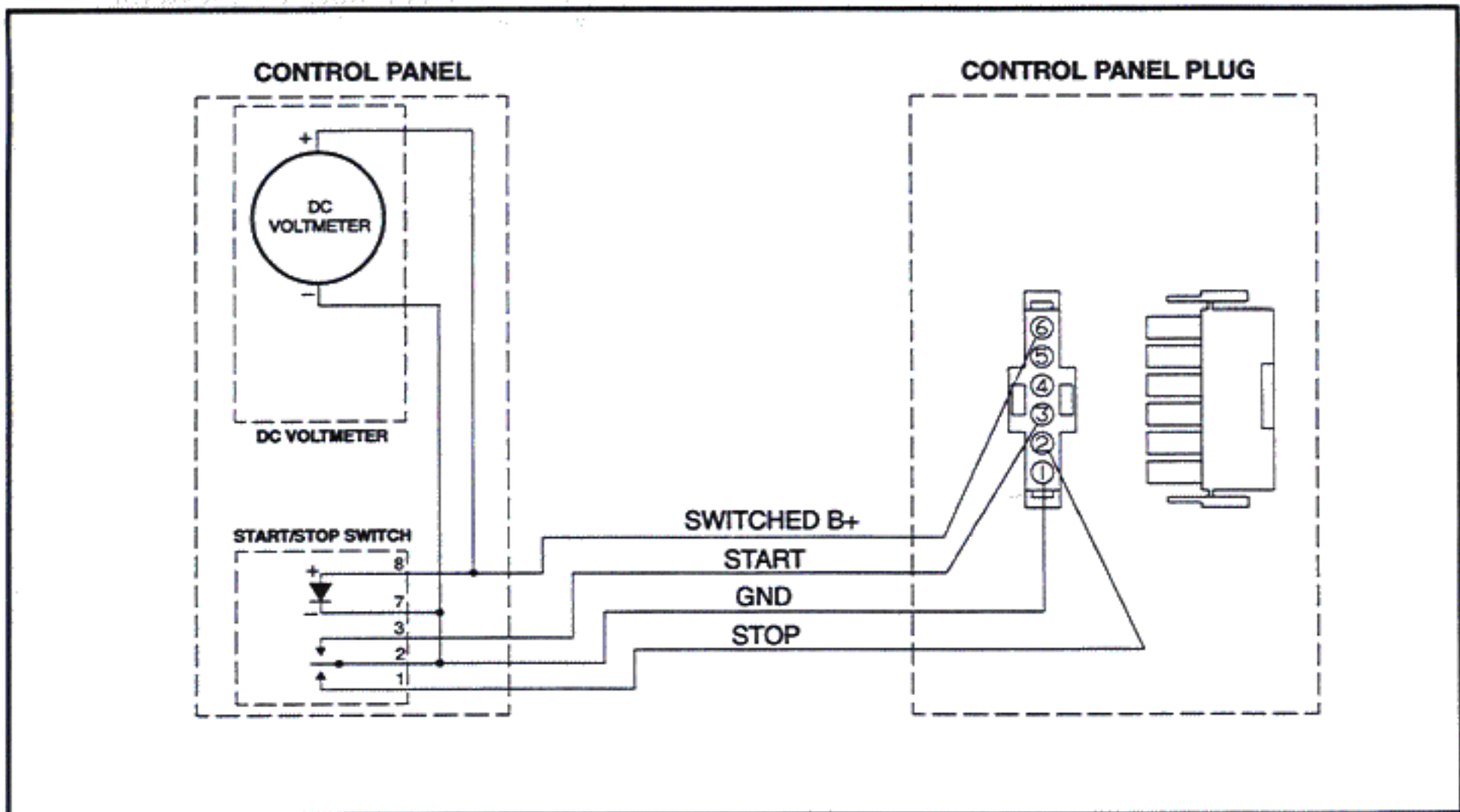

FIGURE 7. KIT 300-4938 REMOTE CONTROL WIRING DIAGRAM

4. Stop the genset at the remote control panel and check the following:
 - a. Genset stops.
 - b. The indicator lamp in the remote switch extinguishes.
 - c. The hour meter stops, if so equipped.
 - d. The DC voltmeter returns to 0, if so equipped.
5. This completes testing the remote control panel.

TROUBLESHOOTING

If any of the panel functions do not operate properly, proceed as follows. Refer to Figures 5, 6, and 7 for wiring diagrams of the remote control panels.

1. Determine if the function operates correctly at the genset control. If it does not, the problem is in the genset, not the remote control panel. See the genset Operator's Manual or Service Manual.
2. If the genset operates correctly from the genset controls but not from the remote panel, the problem is with the remote control panel or the installation.
3. Check all terminal connections on the components on the panel.
4. Check all harness connectors, making sure they are all seated properly.